

**Before**  
**UTTARAKHAND ELECTRICITY REGULATORY COMMISSION**

Petition No. 17 of 2017

**In the matter of:**

Petition for submission of Draft Metering Communication & Data Acquisition Requirements (MCDAR) for Intra-State Transmission System of Uttarakhand developed in pursuance to Regulation 8.1 of UERC (State Grid Code) Regulations, 2016 and Regulation 10 of UERC (Conduct of Business) Regulations, 2014 for approval of the Commission.

**And**

**In the matter of:**

Power Transmission Corporation of Uttarakhand Ltd.,  
'Vidyut Bhawan', Majra,  
Dehradun.

...Petitioner.

**Coram**

**Shri Subhash Kumar    Chairman**

Date of Order: June 19, 2018

**ORDER**

This order relates to the Petition filed by Power Transmission Corporation of Uttarakhand Ltd. (hereinafter referred to as 'PTCUL' or 'the Petitioner' or 'the STU'), seeking approval of the Commission on 'Draft Metering Communication & Data Acquisition Requirements' (MCDAR) for Intra-State Transmission System of Uttarakhand developed in pursuance to Regulation 8.1 of UERC (State Grid Code) Regulations, 2016 and Regulation 10 of UERC (Conduct of Business) Regulations, 2014.

**Background**

2. The Petitioner vide its letter No. 728/MD/PTCUL/UERC dated 17.04.2017 submitted its Petition for submission of Draft Metering Communication & Data Acquisition Requirements (MCDAR) for Intra-State Transmission System of Uttarakhand developed in pursuance to Regulation 8.1 of UERC (State Grid Code) Regulations, 2016 and Regulation 10 of UERC (Conduct of Business) Regulations, 2014 for approval of the Commission.



3. The Petitioner in its Petition has submitted that as per Regulation 8.1 of UERC (State Grid Code) Regulations, 2016, the State Transmission Utility (STU) is required to develop a 'Metering Communication & Data Acquisition Requirements' for each user at the interconnection points and also cross boundary circuits under Chapter 8 (Metering Code) of the aforesaid Regulations and submit the same for approval of the Commission within 90 days of notification of the aforesaid Regulations. The said Regulation is reproduced hereunder:-

“

### 8.1 Metering requirements

- ...
- (2) The MCDAR shall be as per CEA (Installation and Operation of Meters) Regulations, 2006 amended from time to time. Provided that till the time the aforesaid requirements are developed and approved by the Commission, the provisions of prevailing relevant statutes shall be applicable.
- (3) MCDAR developed by STU shall provide the minimum requirements and standards for Installation and Operation of meters, for commercial and operational purposes, to be provided by User or Transmission Licensee at the Connection Point.  
Provided that such requirements shall be consistent with the Regulations as may be specified by the CEA under Section 55 of the Act.  
Provided further that such requirements shall be applicable to any other point that may be internal to the power system of the User or Transmission Licensee if information captured by such meter shall be required for commercial or operational purposes.
- (4) The Commission shall review the MCDAR submitted for approval by the State Transmission Utility and shall either:
- (a) approve the MCDAR, with such conditions or modifications as the Commission may deem appropriate; or
- (b) reject the MCDAR, for reasons to be recorded in writing if the said document is not in accordance with the Act or these Regulations or with the Grid Code specified under clause (h) of sub-section (1) of Section 79 of the Act and direct the State Transmission Utility to submit a revised draft of the same.
- (5) The State Transmission Utility shall put up a copy of the MCDAR on its Internet website and make available a copy of the applicable MCDAR to any person requesting it, at a price not exceeding the reasonable cost of reproducing it.
- (6) MCDAR shall clearly identify the concerned User, responsible for ownership and maintenance of the meters & communication system.
- (7) MCDAR shall include and describe the following:
- (a) provisions related to location and installation of meters;
- (b) specifications and accuracy limits for the meters;
- (c) rights, responsibilities and procedures related to recording, collection, transfer, data acquisition, communication system, processing and storage of data collected from meters;



- (d) provisions related to ownership of metering data;
- (e) calibration procedures to be carried out by each concerned agency to ensure conformance to the above accuracy limits;
- (f) procedures associated with maintenance of the meters in proper functioning state, safety of meters, testing of the new or replacement meters, sealing of meters and inspection of meters;
- (g) provisions related to right of access to the meters;
- (h) procedures to address metering discrepancies, defective equipments and meter failures;
- (i) procedures for resolution of disputes on matters related to metering; and;
- (j) Any other aspect considered appropriate, for inclusion in the MCDAR, by the State Transmission Utility or the Commission. "

4. Incompliance to the same, STU submitted a Draft MCDAR for Intra-State Transmission System of Uttarakhand for approval of the Commission. Subsequent to the aforesaid submission, a series of discussions were held between the Commission's Staff & concerned officers of the Petitioner in the month of July, 2017, September, 2017 & December, 2017 on the draft MCDAR. Based on the aforesaid discussions, the Petitioner vide its letter No. 120/Dir. (projects)/PTCUL/UERC dated 15.01.2018 submitted its Revised draft MCDAR for Intra-State Power System including certain provisions with regard to Distribution System in the Draft MCDAR document submitted to the Commission for Intra-State Transmission System of Uttarakhand..
5. Since, the ambit of the Revised draft MCDAR submitted by the Petitioner was extended from Intra-State Transmission System to Intra-State Power System with inclusion of the provisions pertaining to metering of the consumers of Distribution Licensee (UPCL), therefore, the Revised draft MCDAR was sent to Distribution Licensee for its comments/suggestions on the same.
6. In compliance to the same, UPCL submitted its comments on the clauses pertaining to the metering of consumers connected to the distribution network vide its letter no. 2185/UPCL/Com/ dated 31.05.2018.

**Commission's Observations, Views & Directions:-**

7. The aforesaid submissions of the Petitioner & UPCL have been analysed alongwith the provisions of Regulation 8.1 of UERC (State Grid Code) Regulations, 2016 and 'CEA Metering Regulations' i.e. CEA (Installation and Operation of Meters) Regulations, 2006 and subsequent amendments thereof.



Accordingly, relevant changes have been made in the Revised draft MCDAR in conformity to the aforesaid Regulations.

8. It is known that MCDAR is an integral part of the UERC (State Grid Code) Regulations, 2016. However, the Commission strongly believes that any proposal for change in the clauses of MCDAR may be considered on following grounds :-

- (1) Any amendment in CEA Metering Regulations.
- (2) Any technological advancement in the field of Metering, Communication and Data Acquisition which is vital for the power sector of the State.
- (3) Any other provision which the MCDAR Committee deems fit for inclusion in the MCDAR based on the suggestions of the utilities through their respective Member in the aforesaid Committee subject to approval of the Commission.

9. In light of the above, the Commission hereby approves the 'Metering Communication & Data Acquisition Requirements' (MCDAR) annexed as **Annexure-I** and directs that :-

- (1) The Users/Constituents shall ensure compliance of their respective obligations under the MCDAR.
- (2) The Petitioner shall be responsible for circulating the MCDAR for Intra-State Power System of Uttarakhand with each Users/Constituents of Intra-State Power System.

Ordered accordingly.

  
(Subhash Kumar)  
Chairman

CERTIFIED TRUE COPY

  
AUTH. SIGN.



## Annexure-I

**METERING COMMUNICATION & DATA  
ACQUISITION REQUIREMENTS (MCDAR)  
FOR INTRA-STATE  
POWER SYSTEM OF  
UTTARAKHAND**





## Contents

1.	Introduction.....	1
2.	Objective.....	1
3.	Scope and Applicability.....	2
4.	Reference Standards .....	2
5.	Definitions.....	4
6.	Ownership.....	6
7.	Access to meter.....	7
8.	Safety of meters .....	7
9.	Location of meters .....	8
10.	Installation of meters .....	9
11.	Type of meters .....	9
12.	Specification and Accuracy limits. ....	9
13.	Meter reading and recording .....	16
14.	Rights of access to metering data .....	16
15.	Sealing of meters .....	17
16.	Meter failure or discrepancies.....	18
17.	Calibration and periodical testing of meters .....	20
18.	MCDAR Committee.....	21
19.	Mechanism for Dispute Resolution.....	22
20.	Development of Metering Infrastructure and telemetry requirement.....	22
21.	Dynamic Code.....	23
22.	Quality Assurance of Meters.....	23
23.	Additional meters .....	23
24.	Adoption of new technologies .....	24



# MCDAR FOR INTRA-STATE POWER SYSTEM OF UTTARAKHAND

## 1. Introduction

- 1.1 These requirements may be called Metering Communication & Data Acquisition Requirements (MCDAR) for Intra-State Power System of Uttarakhand and shall come into force immediately on approval of the Commission.
- 1.2 MCDAR prescribes a uniform policy in respect of electricity metering in the Intra- State Power System and provide the minimum requirements and standards for installation and operation of meters for commercial and operational purposes for the State Transmission Utility, Transmission Licensees, Distribution Licensees, Generators and Users connected to Intra-State Power System.
- 1.3 This MCDAR has been prepared by the State Transmission Utility in pursuance of Chapter 8, Metering Code, Regulation 8.1 of the UERC (State Grid Code) Regulations, 2016 and forms the integral part of the UERC (State Grid Code) Regulations, 2016.

## 2. Objective

- 2.1 The MCDAR provides type, standards ownership, location, accuracy class, installation, operation, testing and maintenance, access, sealing, safety, meter reading and recording, meter failure or discrepancies, anti tampering features, quality assurance, error compensation, and periodical testing of meters, additional meters, and adoption of new technologies in respect of following meters for correct accounting, billing and audit of electricity:
  - (i) Interface meters for Intra-State Power system.
  - (ii) Meters for Consumers connected to Intra-State Power System.
  - (iii) Meters for energy accounting and audit in Intra-State Power System.
- 2.2 The objective of the MCDAR is to define **minimum** acceptable metering standards for the purpose of accounting, commercial billing, and settlement of electrical energy in Intra- State Power system and also to provide system information for operation of State power system in economical and efficient manner.



### 3. Scope and Applicability

3.1 This MCDAR for Intra-State Power System shall apply to following in the State of Uttarakhand:

1. Transmission Licensees.
2. Generating Stations connected to Intra-State Transmission System or Distribution Network.
3. Distribution Licensees connected with Intra-State Transmission System.
4. Consumers of Distribution Licensee connected to Intra-State Transmission System or Distribution Network.
5. Transmission System Users connected to Intra-State Transmission System.
6. Open access customers availing open access on Intra-State Transmission System or Distribution network.
7. Captive Generators connected to Intra-State Transmission System.
8. Electricity Traders.
9. Any other consumer not covered in above points 1 to 8 and connected directly or indirectly with Intra State Power System of Uttarakhand.

The provisions for installation and operation of meters in accordance with this MCDAR shall be applicable from the date of approval of Commission.

### 4. Reference Standards

- 4.1 All interface meters, consumer meters and energy accounting and audit meters shall comply with the relevant standards of Bureau of Indian Standards (BIS). If BIS Standards are not available for a particular equipment or material, the relevant British Standards (BS), International Electro-Technical Commission (IEC) Standards, CBIP Technical Report or any other equivalent Standard shall be followed.
- 4.2 Whenever an international Standard or IEC Standard is followed, necessary corrections or modifications shall be made for nominal system frequency, nominal system voltage, ambient temperature, humidity and other conditions prevailing in India before actual adoption of the said Standard.



4.3 The following Indian Standards (amended up to date) shall be applicable as relevant to meters and associated equipment:

Sr. No.	Standard Number	Standard Title
i.	IS 13779	AC Static Watt-hour Meters for Class 1 & 2
ii.	IS 14697	AC Static Transformer Operated Watt-hour and VAR-hour Meters, Class 0.2S and 0.5S
iii.	IS 2705	Indian Standard for Current Transformers
iv.	IS 3156	Indian Standard for Voltage Transformers
v.	IS 9348	Indian Standard for Coupling Capacitors and Capacitor Divider
vi.	IS 5547	Indian Standard for Capacitor Voltage Transformer
vii.	CBIP Technical Report - 88	Specification for AC Static Electrical Energy Meters
viii.	CBIP-88 Guidelines or Latest Guidelines issued by CBIP	Latest Amendments for immunity against external factors
ix.	CBIP Technical Report - 111	Specification for Common Meter Reading Instrument
x.	IS 9000	Basic Environmental Testing Procedures for Electronic & Electrical Items
xi.	IS 12063	Indian Standard for classification of degrees of protection. (IP)

4.4 The following International Standards (amended up to date) can be applicable as relevant to meters and associated equipment not complying to Indian Standards or not manufactured in India:

Sr. No.	Standard Number	Standard Title
i.	IEC 687	Specification for AC Static Watt-hour Meters for Active Energy (Classes 0.2S and 0.5S)
ii.	IEC 62053-22	AC Static Watt-hour meters for Active Energy, Class 0.2S
iii.	IEC 62053-23	AC Static VARh meters for Reactive Energy, Class 0.5
iv.	IEC 1036	Alternating Current Static Watt-hour Meters for Active Energy (Classes 1 & 2)
v.	IEC 1268	Alternating Current Static Watt-hour Meters for Reactive Energy (Classes 2 & 3)

#### 4.5 Standards for installation and operation of meters

The meters and metering equipment shall conform to the requirements of the CEA (Installation & Operations of Meters) Regulations 2006 dated 17<sup>th</sup> March 2007, (including amendments) and standards prescribed there under.



## 5. Definitions

5.1 In the MCDAR for Intra-State Power System of Uttarakhand, the following words and expressions shall, unless the subject matter or context otherwise requires or is inconsistent therewith, bear the meaning given hereunder:

- 1) **'Act'** means the Electricity Act, 2003;
- 2) **'Accredited Test Laboratory'** means a test laboratory accredited by National Accreditation Board for Testing and Calibration Laboratories (NABL);
- 3) **'Active Energy'** means the electricity supplied or consumed during a time interval, being the integral of Active Power with respect to time, measured in the units of 'Watt - hours' or standard multiples thereof. One 'kilowatt - hour' (kWh) is one unit;
- 4) **'Active Power'** means the electrical power, being the product of root mean square (rms) voltage, root mean square (rms) current and cosine of the phase angle between the voltage and current vectors and measured in units of 'Watt' (W) or in standard multiples thereof.
- 5) **'Appropriate Load Despatch Centre'** means 'National Load Despatch Centre' (NLDC) or 'Regional Load Despatch Centre' (RLDC) or the 'State Load Despatch Centre' (SLDC) which includes any 'Area Load Despatch Centre' (ALDC) attached to SLDC as the case may be.
- 6) **'Appropriate Transmission Utility'** means the 'Central Transmission Utility' (CTU) or the 'State Transmission Utility' (STU), as the case may be;
- 7) **'Buyer'** means any generating company or licensee or consumer whose system receives electricity from the system of generating company or licensee;
- 8) **'Check Meter'** means a meter, which shall be connected to the same core of the Current Transformer (CT) and Voltage Transformer (VT) to which main meter is connected and shall be used for accounting and billing of electricity in case of failure of main meter;
- 9) **'Consumer Meter'** means a meter used for accounting and billing of electricity supplied to the consumers but excluding those consumers covered under Interface Meters;



- 10) **'Correct Meter'** means a meter, which shall at least have, features, Accuracy Class and specifications as per the clause 12 and 15 of these requirements;
- 11) **'Energy Accounting and Audit Meters'** means meters used for accounting of the electricity to various segments of electrical system so as to carry out further analysis to determine the consumption and loss of energy therein over a specified time period;
- 12) **'Instrument Transformer'** means the **'Current Transformer'** (CT), **'Voltage Transformer'** (VT) and **'Capacitor Voltage Transformer'** (CVT);
- 13) **'Interface Meter'** means a meter used for accounting and billing of electricity, connected at the point of interconnection between electrical systems of generating company, licensee and customers directly connected to the Inter-State Transmission System or Intra-State Power System, and have been permitted open access by the Appropriate Commission;
- 14) **'Main Meter'** means a meter, which would primarily be used for accounting and billing of electricity;
- 15) **'Meter'** means a device suitable for measuring, indicating and recording consumption of electricity or any other quantity related with electrical system and shall include, wherever applicable, other equipment such as Current Transformer (CT), Voltage Transformer (VT) or Capacitor Voltage Transformer (CVT) or Lead Cables necessary for such purpose;
- 16) **'Power Factor'** means the cosine of the electrical angle between the voltage and current vectors in an AC electrical circuit;
- 17) **'Reactive Energy'** means, the integral of Reactive Power with respect to time and measured in the units of **'Volt-Ampere hours reactive (VARh)** or in standard multiples thereof;
- 18) **'Reactive Power'** means the product of root mean square (rms) voltage, root mean square (rms) current and the sine of the electrical phase angle between the voltage complexor and current complexor, measured in **'Volt - ampere reactive' (VAR)** and in standard multiples thereof;
- 19) **'Special Energy Meters'** means such meters, of not less than 0.2S class accuracy, as are capable of:



- i. Recording time-differentiated measurements of active energy and voltage differentiated measurement of reactive energy, at intervals of fifteen (15) minutes.
  - ii. Storing such measurements for not less than forty-five (45) days and
  - iii. Communication of such measurements at such intervals as maybe required by the State Load Despatch Centre for balancing and settlement of energy transactions;
- 20) 'Standards' means Standards on Installation and Operation of Meters given in these requirements unless otherwise any other standard specifically referred;
- 21) 'Standby Meter' means a meter connected to CT and VT, other than those used for main meter and check meter and shall be used for accounting and billing of electricity in case of failure of both main meter and check meter;
- 22) 'Supplier' means any generating company or licensee from whose system electricity flows into the system of another generating company or licensee or consumer;
- 23) 'Time of the Day (TOD) Meter' means a meter suitable for recording and indicating consumption of electricity during specified time periods of the day.
- 5.2 All other words and expressions used and not defined herein have the meanings respectively assigned to them in the Act, the UERC (State Grid Code) Regulations, 2016 or Indian Electricity Grid Code (IEGC) and amendments thereof.

## 6. Ownership

### 6.1 Interface meters

- 6.1.1 All interface meters installed at the points of interconnection with Intra-State Transmission System excluding meters installed at the points of interconnection with Inter-State Transmission System (ISTS) for the purpose of electricity accounting and billing shall be owned by STU.
- 6.1.2 Interface Meters installed at the points of interconnection with Inter-State Transmission System (ISTS) for the purpose of electricity accounting and billing shall be owned by CTU.
- 6.1.3 All interface meters installed at the points of inter connection between the two licensees excluding those covered under sub-clauses (6.1.1) and (6.1.2) above for the purpose of electricity accounting and billing shall be owned by respective licensee of each end.



6.1.4 All interface meters installed at the points of inter connection for the purpose of electricity accounting and billing not covered under above sub-clauses shall be owned by supplier of electricity and in case of Open Access Customers ownership shall be as per Uttarakhand Electricity Regulatory Commission (Terms and Conditions of Intra-State Open Access) Regulations, 2015 and amendments thereof.

6.1.5 Pictorial representation of ownership of meters for Intra-State Power System has been depicted at **Annexure-A**.

## 6.2 Consumer Meters

- a) Consumer Meters shall generally be owned by the distribution licensee.
- b) If any HV consumer elects to purchase a meter, the same may be purchased by him, based on the specifications given in these requirements and of make and model approved by the licensee. The meter purchased by the consumer shall be tested, installed and sealed by the distribution licensee. The consumer shall claim the meter purchased by him as his asset, only after it is permanently removed from the system of the licensee.

6.3 **Energy accounting and audit meters** shall be owned by the Generating Company or licensee, as the case may be.

6.4 **Meters of EHV consumer** shall be owned by the Distribution licensee or owned by the party as provided in the Agreement.

## 7. Access to meter

The owner of the premises where, the meter is installed shall provide access to the authorized representative(s) of the other entities for installation, testing, commissioning, reading, and recording and maintenance of meters.

## 8. Safety of meters

8.1 The supplier or buyer in whose premises the interface meters are installed shall be responsible for their safety.

8.2 The consumer shall take precautions for the safety of the consumer meter installed in his premises belonging to the licensee.

8.3 The generating company or the licensee who owns the energy accounting and audit meters shall be responsible for its safety.



9. Location of meters

9.1 The location of meters at interface meters, meters for energy accounting audit and meters of EHV consumer shall be as given in Table-1.

**Table-1**

Interface Points	Main Meter	Check Meter	Standby Meter	Energy accounting and audit meter
	MMIT	CMIT	SMIT	MEAA
<b>At all Generating Stations</b>				
Generation-Transmission/Distribution (G-T/D) interface points	On all outgoing feeders	On all outgoing feeders	1. High Voltage (HV) Side of Generator Transformer (GT). 2. High Voltage (HV) Side of all Station Auxiliary Transformers (SAT).	1. At a point after the Generator Stator Terminal and before the tap-off to the Unit Auxiliary Transformer(s). 2. LV side of all UAT and SAT. 3. On all High Tension Motor Feeders.
<b>Interface points between Transmissions - Distribution.</b>				
	On all outgoing feeders to Distribution Licensees		1. Meter installed at the incoming feeder at the sub-station / Receiving station of Distribution licensee. 2. LV side of EHV transformer at the EHV sub-station / Receiving station of the Transmission Licensee.	
<b>Interface points between two Transmission Licensees</b>				
	At the sub-station/receiving station of each Transmission licensee		The meter at the other end of the line shall be considered standby meter.	
<b>Interconnecting Transformer</b>				
At generating station or at sub-station/receiving station of Transmission licensee, connected to the IaSTS.	High Voltage side of ICT		Low Voltage side of the ICT (connected to the IaSTS).	
<b>HV/EHV Consumers</b>				
HV/EHV Consumers	On outgoing feeder at the sub-station of the Licensee.  OR At the consumer premises at the connection point of the feeders as per Distribution code and amendments thereof.	To be located at the same location as where Main Meter is located on the same Instrument transformer cores.		
<b>Open Access Customers</b>				
Open Access Customers	At the Open Access Customer end.	To be located at the same location as where Main Meter is located on the same Instrument transformer cores.		



## 10. Installation of meters

- 10.1 State Transmission Utility (STU), Generating Company or Transmission / Distribution licensee, as the case may be, shall examine, test, and regulate all meters before installation and only correct meters shall be installed.
- 10.2 The meter shall be installed at locations, which are easily accessible for installation, testing, commissioning, reading, recording, and maintenance. The place of installation of meter shall be such that minimum inconvenience and disruptions are caused to the site owners and the concerned organizations.

## 11. Type of meters

- 11.1 All the meters at interface point, meters for energy accounting and audit and consumers' meters shall be of static type.
- 11.2 The meters not complying with these requirements shall be replaced by the State Transmission Utility (STU) or concerned licensee/generating company as the case may be within a period of six months from the date of coming of these requirements in effect.
- 11.3 The Static meters, related hardware, the communication system and the related software shall be such that progressive up-gradation to the newer technologies for improved facilities of data transfer, data security, user friendliness etc shall be possible without undergoing major replacements.

## 12. Specification and Accuracy limits.

### 12.1 Functional requirements

#### 12.1.1 Interface Meters:

- a) The Interface meters shall be static type, composite meters, as self-contained devices for measurement of active and reactive energy, and certain other parameters as described in the following paragraphs. The meters shall be suitable for being connected directly to voltage transformers (VTs) having a rated secondary line-to-line voltage of 110 V, and to current transformers (CTs) having a rated secondary current of 1 Amp (Model-A: 3 element 4 wire) or 5 Amp (model-B: 3 element, 4 wire). The reference frequency shall be 50Hz.
- b) The meters shall have a non-volatile memory in which the following shall be automatically stored:
- (i) Average frequency for each successive 15-minute block, as a two digit code (00



- to 99 for frequency from 49.0 to 51.0 Hz).
- (ii) Net Wh transmittal during each successive 15-minute block, upto second decimal. With plus/minus sign.
  - (iii) Cumulative Wh transmittal at each midnight, in six digits including one decimal.
  - (iv) Cumulative VARh transmittal for voltage high condition, at each midnight, in six digits including one decimal.
  - (v) Cumulative VARh transmittal for voltage low condition, at each midnight, in six digits including one decimal.
  - (vi) Date and time blocks of failure of VT supply on any phase, as a star (\*) mark.
  - (vii) Separate registers for the Active energy Import and Active energy Export.
- c) The meters shall store all the above listed data in their memories for a period of at least forty-five days. The data older than 45 days shall get erased automatically on First-in First-out (FIFO) basis. Each meter shall have an optical port on its front for tapping all data stored in its memory using a hand held data collection device (i.e. CMRI). The meters shall have at-least one RS-485 and Ethernet LAN port suitable for transmitting the data to remote location using appropriate communication medium. The communication protocol shall be open protocol and shall not be proprietary nature.
- d) It shall be possible to reprogramme at site only those parameters, which do not affect the integrity of the data or basic settings of the meters. Reprogramming of critical parameters such as CT Ratio, PT Ratio, ToD registers, manual clock corrections etc, at site, shall be possible. Use of multiple level passwords for the above purpose shall be provided to avoid accidental re-programming when different entities are sharing the meter for data downloading.
- e) The active energy (Wh) measurement shall be carried out on 3-phase, 4-wire principle, with accuracy as per class 0.2 S of IEC-687/IEC-62053-22 or better. The meters shall be programmed for primary connected ratio of CT and PT, and accordingly energy shall be displayed in proper units (Mega/Giga).
- f) The reactive power and reactive energy measurement shall also be on 3-phase, 4-wire principle, with accuracy as per class 0.5 of IEC-62053-23 or better. The reactive



power and reactive energy computation shall be directly in CT and VT secondary quantities. There shall be separate reactive energy registers, one for the period when average RMS voltage is above 103% and the other for the period the voltage is below 97%. In addition to these voltage triggered registers, four registers shall be made available by the meter for four-quadrant reactive energy measurement.

- g) The 15 minutes active energy shall be considered as import when active energy flow is incoming towards substation bus bar and export when active energy flow is outgoing from substation bus bar. Separate integrating cumulative registers shall be maintained for active import and active export energy. Reactive energy logging (cumulative registers) shall be based on true four quadrant metering.
- h) The meters shall also display (on demand), by turn, the following parameters:
- i. Unique identification number of the meter
  - ii. Date
  - iii. Time
  - iv. Import and Export active energy reading.
  - v. Average frequency of the previous 15-minute block.
  - vi. Import & Export active energy transmittal in the previous 15 minutes block.
  - vii. Average percentage voltage.
  - viii. True four quadrant Reactive energy
  - ix. Voltage-high Reactive energy register reading .
  - x. Voltage-low Reactive energy register reading.
  - xi. Instantaneous phase voltages.
  - xii. Instantaneous line currents
  - xiii. Instantaneous value of average power factor of three phases.
  - xiv. Previous months billing history for active import energy and active export energy.
  - xv. A key pad shall be provided on the metering system front for switching on display and for changing from one indication to the next. Auto display shall also be supported by the meter.



- i) The three line-to-neutral voltages (phase voltages) shall be continuously monitored, and in case any of these falls below 70%, the low voltage condition shall be suitably indicated and recorded. Each meter shall have a built-in calendar and clock, having an accuracy of 30 seconds per month or better.
- j) The meters shall be totally sealed and tamper-proof, with no possibility of any adjustment at site.
- k) Billing will be based on total energy/energy at fundamental frequency. The meter should measure total energy and energy at fundamental frequency in separate registers.
- l) The Main meter and the Check meter shall be connected to same core of CTs and VTs.
- m) The energy meters shall be capable to receive periodic time synchronization signals via proper on line system. The meter time shall be in synch with GPS system.

#### 12.1.2 Consumer Meters: (Measuring Parameters)

- a) The consumer meter shall be suitable for measurement of cumulative active energy utilized by the consumer.
- b) The consumer meter may have the facilities to measure, record and display one or more of the following parameters depending upon the tariff requirement for various categories of consumers. All parameters excluding instantaneous electrical parameters shall also be stored in memory.
  - i) Cumulative reactive energy.
  - ii) Average power factor.
  - iii) Time of use of energy.
  - iv) Apparent power.
  - v) Maximum demand.
  - vi) Phase voltage and line currents.
  - vii) Cumulative apparent energy (kVAh).
  - viii) Any other parameter required for tariff application or analysis.



- c) The meters shall store all the above listed data in their memories for a period of at least forty-five days. The data older than 45 days shall get erased automatically on First-in First-out (FIFO) basis. Each meter shall have an optical port/RS 232 port for tapping all data stored in its memory using a hand held data collection device (i.e. CMRI). The communication protocol shall be open protocol and shall not be of proprietary nature.

**12.1.3 Energy Accounting and Audit Meters: (Measuring parameters)**

- a) The energy accounting and audit meters shall be suitable for measurement, recording, and display of cumulative active energy with date and time.
- b) The meters installed at transmission level shall be as per the specifications of interface meters as specified at clause 12.1.1 above.
- c) The meters installed at Distribution (at each feeder, 'T' points, DTs and consumers in the distribution network) and Generation Company level shall have a non-volatile memory in which the following shall be automatically stored:
- i) Apparent power.
  - ii) Phase-wise kilowatt at peak kVA.
  - iii) Phase-wise kVA (reactive) at peak kVA.
  - iv) Phase-wise voltage at peak kVA.
  - v) Power down time.
  - vi) Average power factor.
  - vii) Line currents.
  - viii) Phase voltages.
  - ix) Date and time.
  - x) Tamper events.
  - xi) Cumulative apparent energy (kVAh).
  - xii) Any other parameter required for tariff application or analysis.
- d) The meters shall store all the above listed data in their memories for a period of at least forty-five days. The data older than 45 days shall get erased automatically on First-in First-out (FIFO) basis. Each meter shall have an optical port on its front for



tapping all data stored in its memory using a hand held data collection device (i.e. CMRI). The meters shall have at-least one RS-485 and Ethernet LAN port suitable for transmitting the data to remote location using appropriate communication medium. The communication protocol shall be open protocol and shall not be proprietary nature.

### 12.2 Accuracy Class:

The specification of the main meters and check meters for interface points, meters for energy accounting and audit, and standby meters is given in Table-2.

<b>Standard Reference Voltage</b>	As per IS												
<b>Voltage Range</b>	The meter shall work satisfactorily on 110 Volts AC (Line-Line) with voltage variation range as per IS												
<b>Standard Frequency</b>	The meter shall work satisfactorily on 50 Hertz with variation range of -5% to +5%.												
<b>Standard Basic Current</b>	As per IS (Current range of consumer meters shall be so chosen as to record the load current corresponding to the sanctioned load)												
<b>Accuracy Class*</b>	<p>Meters shall meet the following requirements of Accuracy Class:</p> <table border="1" style="width: 100%; border-collapse: collapse;"> <tr> <td style="text-align: center;">Interface meters</td> <td>0.2S (active) 0.5 or better (reactive)</td> </tr> <tr> <td colspan="2" style="text-align: center;"><b>consumer meters</b></td> </tr> <tr> <td style="text-align: center;">Up to 650 volts</td> <td>1.0 or better</td> </tr> <tr> <td style="text-align: center;">Above 650 volts and up to 33 kV</td> <td>0.5S or better</td> </tr> <tr> <td style="text-align: center;">Above 33 kV</td> <td>0.2S</td> </tr> <tr> <td style="text-align: center;">Energy accounting and audit meters</td> <td> <p>The accuracy class of meters in generation and transmission system shall not be inferior to that of 0.2S Accuracy Class.</p> <p>The accuracy class of meters in distribution system shall not be inferior to that of 0.5S Accuracy Class</p> </td> </tr> </table>	Interface meters	0.2S (active) 0.5 or better (reactive)	<b>consumer meters</b>		Up to 650 volts	1.0 or better	Above 650 volts and up to 33 kV	0.5S or better	Above 33 kV	0.2S	Energy accounting and audit meters	<p>The accuracy class of meters in generation and transmission system shall not be inferior to that of 0.2S Accuracy Class.</p> <p>The accuracy class of meters in distribution system shall not be inferior to that of 0.5S Accuracy Class</p>
Interface meters	0.2S (active) 0.5 or better (reactive)												
<b>consumer meters</b>													
Up to 650 volts	1.0 or better												
Above 650 volts and up to 33 kV	0.5S or better												
Above 33 kV	0.2S												
Energy accounting and audit meters	<p>The accuracy class of meters in generation and transmission system shall not be inferior to that of 0.2S Accuracy Class.</p> <p>The accuracy class of meters in distribution system shall not be inferior to that of 0.5S Accuracy Class</p>												
<b>Starting Current and Maximum Current</b>	As per IS												
<b>Power Factor Range</b>	The meter shall work satisfactorily over a power factor range of zero lag to unity to zero lead												
<b>Power Frequency Withstand Voltage</b>	As per IS												
<b>Impulse Voltage Withstand Test for 1.2/50 micro sec</b>	As per IS												
<b>Power Consumption</b>	As per IS												



\* The accuracy class of Current transformers (CTs) and Voltage transformers (VTs) shall not be inferior to that of associated meters. The existing CTs and VTs not complying with these requirements shall be replaced by new CTs and VTs, if found defective, non-functional or as per the directions of the Appropriate Commission. In case the CTs and VTs of the same Accuracy Class as that of meters cannot be accommodated in the metering cubicle or panel due to space constraints, the CTs and VTs of the next lower Accuracy Class can be installed.

### 12.3 Data download capability of Meters

All meters shall have downloading facilities of metered data through Common Meter Reading Instrument (CMRI). CMRI shall be capable of downloading data/information from various makes of AC static energy meters when loaded with the corresponding meter specific downloading software(s) called meter reading instrument programs. The CMRI shall be able to extract information about energy data, load survey data, billing parameters, meter status, meter anomaly and tamper data from the memory of the meter and store for retrieval at a later stage.

Anti-tampering features shall be reviewed from time to time as mutually agreed by the concerned licensees and the meter shall be able to store at least 100 tamper events on FIFO basis ; which includes PT miss, CT reversal, Voltage unbalance, Current unbalance and power on/off.

### 12.4 Immunity to External Factors

The meter shall be immune to external influences like magnetic induction, vibration, electrostatic discharge, switching transients, surge voltages, oblique suspension, and harmonics and necessary tests shall be carried out in accordance with relevant standard.

### 12.5 Accuracy class of CTs & VTs

The accuracy class of Current transformers (CTs) and Voltage transformers (VTs) shall preferably not be inferior to that of associated meters. The existing CTs and VTs not complying with these requirements shall be replaced by new CTs and VTs in a phased manner. The State Transmission Utility in consultation with concerned Transmission Licensee and Generating Company shall prepare a phased programme for replacement of all CTs & PTs having accuracy limit of metering core(s) inferior to associated meters.

The Voltage Transformers shall be electromagnetic VT or Capacitive Voltage Transformer (CVT).



## **12.6 Lead Cables**

Lead Cables of CTs and PTs shall be of sufficient cross-section for reducing voltage drop to minimum between end connections (connection between cable lead end and CT/PT terminal as well as between cables lead and meter terminals). No joints shall be allowed in lead cables. The burden on metering cores of CTs and PTs including burden of lead cable and meters connected thereto shall not exceeds rated burden.

## **13. Meter reading and recording**

### **13.1 Interface Meters**

It shall be the responsibility of the State Transmission Utility (STU)/Licensee to take down the meter reading and record the metered data, maintain database of all the information associated with the interface meters and verify the correctness of metered data and furnish the same to various agencies as per agreed procedure. Details of the agreed procedure pertaining to each Interface point shall be properly documented and shall be intimated to the Commission for record.

### **13.2 Energy accounting and audit meters**

It shall be the responsibility of the concerned generating company or licensee to record the metered data, maintain database of all the information associated with the energy accounting and audit meters and verify the correctness of metered data. Each generating company or licensee shall prepare quarterly, half-yearly and yearly energy account for its system for taking appropriate action for efficient operation and system development.

### **13.3 Meters of Consumers**

It shall be the responsibility of the distribution licensee to record the metered data, maintain database of all the information associated with the consumer meters and verify the correctness of metered data. The licensee shall maintain accounts for the electricity consumption and other electrical quantities of its consumers. Brief history, date of installation and details of testing, calibration and replacement of meters shall be maintained by the licensee.

## **14. Rights of access to metering data**

14.1 Authorised representatives of the following entities shall be entitled to have access to the metering data from the metering installations:

- a) Generating Company, Transmission Licensee, Distribution Licensee, CPP and STU as the case may be who is responsible for the metering installation;



- b) The State Load Dispatch Centre;
- c) The State Transmission Utility;
- d) The consumer of electricity or the generator of electricity at the metering installation as the case may be;
- e) Any other person who has an authorisation from persons at S. No. a, b & c or from Commission; and
- f) The Commission.

## 15. Sealing of meters

### 15.1 Sealing Arrangements

All meters shall be sealed by the manufacturer at its works. In addition to the seal provided by the manufacturer at its works, the sealing of all meters shall be done as follows at various meter sealing points.

- (i) Sealing of interface meters, shall also be done by both, the supplier and the buyer.
- (ii) Sealing of consumer meters shall be done by the licensee.
- (iii) Sealing of energy accounting and audit meters shall be done by the licensee or generating company as the case may be.

### 15.2 Sealing Points

Sealing shall be done at the following points (as applicable):

- (i) Meter body or cover
- (ii) Meter terminal cover
- (iii) Meter test terminal block
- (iv) Meter cabinet
- (v) The CT & VT secondary terminals terminated in the panel links
- (vi) Monitoring Seals & Sealing Records
  - a) A tracking and recording software for all new seals shall be provided by the manufacturer of the meter so as to track total movement of seals starting from manufacturing, procurement, storage, record keeping, installation, series of inspections, removal and disposal.



- b) Seal shall be unique for each utility and name or logo of the utility shall be clearly visible on the seals.
- c) Only the patented seals (seal from the manufacturer who has official right to manufacture the seal) shall be used.
- d) Polycarbonate or acrylic seals or plastic seals or holographic seals or any other superior seals shall be used.
- e) Lead seals shall not be used in the new meters installed at consumer premises. Old lead seals shall be replaced by new seals in a phased manner and the time frame of the same shall be submitted by the licensee to the Commission for approval.

### 15.3 Removal of seals from meters

#### 15.3.1 Interface meters

Whenever seals of the interface meters have to be removed for any reason, advance notice shall be given to other party for witnessing the removal of seals and resealing of the interface meter. The breaking and re-sealing of the meters shall be recorded by the party, who carried out the work, in the meter register, mentioning the date of removal and resealing, serial numbers of the broken and new seals and the reason for removal of seals.

#### 15.3.2 Consumer meters

Seal of the consumer meter shall be removed only by the licensee. No consumer shall tamper with, break or remove the seal under any circumstances. Any tampering, breaking, or removing the seal from the meter shall be dealt with as per relevant provisions of the Act and Supply Code applicable.

#### 15.3.3 Energy accounting and audit meters

Seal of the energy accounting and audit meter shall be removed only by the authorized person of generating company or the licensee as the case may be who owns the meter.

## 16. Meter failure or discrepancies

### 16.1 Interface meters

- a) Whenever difference between the readings of the Main meter and the Check meter for any month is more than 0.5%, the following steps shall be taken:



- (i) Checking of CT and VT connections;
- (ii) Testing of accuracy of interface meter at site with reference standard meter of accuracy class higher than the meter under test.

If the difference exists even after such checking or testing, then the defective meter shall be replaced with a correct meter.

- b) In case of conspicuous failures like burning of meter and erratic display of metered parameters and when the error found in testing of meter is beyond the permissible limit of error provided in the relevant standard, the meter shall be immediately replaced with a correct meter.
- c) In case where both the Main meter and Check meter fail, at least one of the meters shall be immediately replaced by a correct meter by the STU/licensee official in presence of authorised representatives from concerned licensee/Customer.

#### 16.1.1 Billing for the failure period

- a) The billing for the failure period of the meter shall be done as per the procedure laid down in the respective agreement such as PPA or as may be directed by the Commission.
- b) Readings recorded by Main, Check and Standby meters for every time slot shall be analysed, crosschecked and validated by STU and SLDC. The discrepancies, if any, noticed in the readings shall be informed by the SLDC in writing to the energy accounting agency for proper accounting of energy. SLDC shall also intimate the discrepancies to the State Transmission Utility or the concerned licensee or generating company as the case may be who shall take further necessary action regarding testing, calibration or replacement of the faulty meters in accordance with the provisions laid down.
- c) The defective meter shall be immediately tested and calibrated.

#### 16.2 Meters of Consumer

In case the consumer reports to the distribution licensee about consumer meter readings not commensurate with his consumption of electricity, stoppage of meter, damage to the seal, burning or damage of the meter, the licensee shall take necessary steps as per the procedures given in the Electricity Supply Code of the Commission read with the notified conditions of supply of electricity.



### 16.3 Energy accounting and audit meters

Energy accounting and audit meters shall be rectified or replaced by the concerned generating company or licensee immediately after notice of any of the following abnormalities:

- a) The errors in the meter readings are outside the limits prescribed for the specified Accuracy Class;
- b) Meter readings are not in accordance with the normal pattern of the load demand;
- c) Meter tampering, or erratic display or damage.

## 17. Calibration and periodical testing of meters

### 17.1 Interface meter

- a) At the time of commissioning, each interface meter shall be tested by the owner at site for accuracy using standard reference meter of better accuracy class than the meter under test.
- b) All interface meters shall be tested at least once in five years. These meters shall also be tested whenever the energy and other quantities recorded by the meter are abnormal or inconsistent with electrically adjacent meters. Whenever there is unreasonable difference between the quantity recorded by interface meter and the corresponding value monitored at the billing center via communication network, the communication system and terminal equipment shall be tested and rectified. The meters may be tested using NABL accredited mobile laboratory or at any accredited laboratory and recalibrated if required at manufacturer's works.
- c) Testing and calibration of interface meters may be carried out in the presence of the representatives of the supplier and buyer. The owner of the meter shall send advance notice to the other party regarding the date of testing.

### 17.2 Consumer meters

The testing of all EHV consumer meters shall be done at site by the distribution licensee at least once in a year or at such interval given in Electricity Supply Code Regulations and amendments thereof. The Distribution Licensee may instead of testing the meter at site can remove the meter and replace the same by a tested meter duly tested in an accredited test laboratory. In addition, meters installed in the consumer premises shall be tested if upon study of consumption pattern it is found that said pattern has changed drastically



w.r.t. similar months or season of the previous years or if there is consumer's complaint pertaining to a meter. The standard reference meter of better accuracy class than the meter under test shall be used for site testing of consumer meters up to 650 volts. The testing for consumer's meters above 650 volts should cover the entire metering system including CTs, VTs. Testing may be carried out through NABL accredited mobile laboratory using secondary injection kit, measuring unit and phantom loading or at any accredited test laboratory and recalibrated if required at manufacturer's works.

### 17.3 Energy accounting and audit meters

Energy accounting and audit meters shall be tested at site at least once in five years or whenever the accuracy is suspected or whenever the readings are inconsistent with the readings of other meters, e.g., check meters, standby meters. The testing must be carried out without removing the CTs and VTs connection. Testing may be carried out through NABL accredited mobile laboratory using secondary injection kit, measuring unit and phantom loading or at any accredited test laboratory and recalibrated if required at manufacturer's works.

## 18. MCDAR Committee

18.1 State Transmission Utility shall be responsible for managing and serving the MCDAR for Intra-State Power System of Uttarakhand with each constituents/Users of Intra-State Power System discharging respective obligations under the MCDAR.

18.2 The GCC shall also work as MCDAR Committee and in case any specialist member is required, GCC may nominate from the State Constituents.

18.3 The rules to be followed by the Committee in conducting their business shall be formulated by the Committee itself and shall be approved by Grid Coordination Committee. The Committee shall meet at least once in six (6) months and conduct the following functions:

- (a) To keep MCDAR for Intra-State Power System and its working under scrutiny and review.
- (b) To consider all requests for amendment to the MCDAR for Intra-State Power System which any user makes.
- (c) To publish recommendations for changes to the MCDAR for Intra-State Power System together with the reason for the change and any objection if applicable.

Who are  
Committee  
members



- (d) To issue guidance on the interpretation and implementation of the MCDAR. Any amendments and changes recommended by the MCDAR committee and subsequently approved by the Grid-coordination committee shall be put up to the Commission for approval before they become effective.

#### 19. Mechanism for Dispute Resolution

Any disputes relating to metering amongst STU, other transmission licensees, Transmission system user of IaSTS, any Generating Company, Distribution licensees in Uttarakhand, any traders registered in Uttarakhand, any EHV consumer connected directly to the IaSTS and any disputes relating to inter-utility metering between STU and any Generating Company/Distribution Licensees/Users shall be settled in accordance with procedures given in UERC (State Grid Code) Regulations, 2016/UERC (Distribution Code) Regulations, 2018. The dispute relating to billing and settlement among the entities shall be resolved under relevant agreements like Power Purchase Agreements (PPA) and Connection Agreement etc.

#### 20. Development of Metering Infrastructure and telemetry requirement

- 20.1 For proper energy audit and accounting and deviation settlement in the state different constituents of the state power system will develop and maintain an infrastructure as follows-
- a) SLDC will develop a data centre for collecting energy meter data of all interface meters (of both ends including distribution licensee ends and generator ends also), energy accounting meters of STU and Transmission Licensee and perform proper energy audit and accounting and deviation settlement work. SLDC and STU can also ask for providing the data automatically or otherwise, of any energy meter from any of the constituents of Uttarakhand State Power System which they think is required for the energy audit and accounting work.
  - b) STU and Transmission Licensee will develop an infrastructure for metering to communicate interface and energy accounting meters data with SLDC.
  - c) All the generators including RE generators of the state will develop an infrastructure for metering to communicate interface energy meters data with SLDC.
  - d) All the distribution licensees in the state will develop an infrastructure for metering to communicate the data of their end interface energy meters, consumer energy meters of consumers at 33 kV and above voltage level & Open Access customer energy meters with SLDC.



20.2 Distribution Licensee in the state should ensure the automatic meter reading to every consumer connected on 11 kV and above voltage level:-

- a) By September, 2018 for consumers covered under Deviation Settlement Mechanism.
- b) By March, 2019 for consumers not covered under Deviation Settlement Mechanism.

20.3 STU, Transmission Licensee and Generators will install and maintain telemetry equipments at their end to communicate their real time data to SLDC which is necessary for real time grid operation.

## 21. Dynamic Code

The MCDAR requires review and updation from time to time in view of continuously and fast changing metering and communication technology and for new commercial agreements and tariff, industry structure. All changes and revision in the MCDAR shall be discussed in MCDAR Committee and approved by the Commission.

## 22. Quality Assurance of Meters

The licensee, Generating Company, CPP/Co-generating plant, Distribution licensee and consumers who are responsible for procurement and/or installation and commissioning of the meters covered under these requirements shall ensure that all type, routine and acceptance tests are performed by the suppliers satisfactorily on these meters before they are commissioned. Subsequent to commissioning of the meters at site, the owners of the meters and the entities responsible for satisfactory functioning of the meters shall draw up a plan for routine maintenance / testing of the meters in line with Regulation 17 above and shall submit the same to the MCDAR committee for approval.

## 23. Additional meters

23.1 In addition to any meter placed by the licensee for recording the electricity consumed by the customer or by distribution licensee, the licensee may connect additional meters, maximum demand indicators or other apparatus as he may think fit for the purpose of ascertaining or regulating either the quantity of electricity supplied or the number of hours of supply or combination of both for summation purposes.

23.2 The customers may, in consultation with the supplier, install appropriate meters with reasonable level of accuracy to support the load management plans stipulated by the supplier. Any charges of electricity supplied to the customers, based on the readings of the above meters shall be as per the agreement between the parties or as per the code of



supply as the case may be.

**24. Adoption of new technologies**

The distribution licensees and consumers shall make out plans for introduction and adoption of new technologies which will be useful in integrating with the suppliers and other entities in the State, the Demand Side Management (DSM) efforts and energy conservation programmers.



## Type &amp; Ownership of Meters

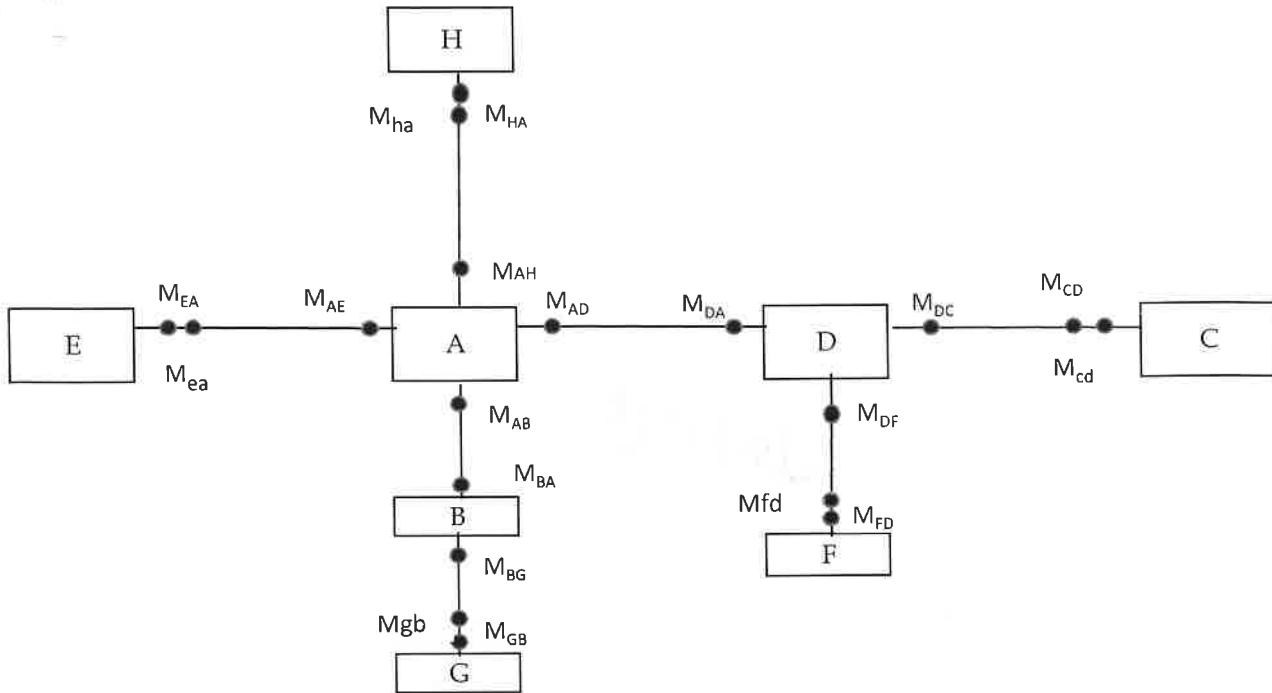

## Type &amp; Ownership of Meters:-

- (i)  $M_{AB}$  &  $M_{BA}$  are Energy Accounting & Audit Meters owned by STU/TL installed at the feeder.
- (ii)  $M_{BG}$ ,  $M_{gb}$  &  $M_{GB}$  are interface meters.  $M_{BG}$  is owned by STU/TL.  $M_{gb}$  &  $M_{GB}$  are Main & Check meters owned by Generator.
- (iii)  $M_{AD}$  &  $M_{DA}$  are interface meters owned by STU/TL & Distribution Licensee respectively.
- (iv)  $M_{DF}$  is interface meter owned by distribution licensee installed at outgoing feeder at sub-station.
- (v)  $M_{fd}$  &  $M_{FD}$  are Check & Main interface meters owned by distribution licensee installed at Open access customer (including generators) premises.
- (vi)  $M_{DC}$  is Energy Accounting & Audit Meters owned by Distribution Licensee installed at outgoing feeder of sub-station.
- (vii)  $M_{cd}$  &  $M_{CD}$  are Check & Main Consumer meters owned by Distribution Licensee.
- (viii)  $M_{AE}$  is interface meter owned by STU.  $M_{ea}$  &  $M_{EA}$  are Check & main consumer meter installed at EHV consumer owned by Distribution Licensee.
- (ix)  $M_{ha}$  &  $M_{HA}$  are Check & Main interface meters owned by Distribution licensee installed at Open access customer (including generators) premises.
- (x)  $M_{AH}$  is interface meter owned by STU/TL installed at outgoing feeder at sub-station.

Where:-

- A, B  $\rightarrow$  S.T.U./Transmission Licensee (TL)
- C  $\rightarrow$  Consumer
- D  $\rightarrow$  Distribution Licensee
- E  $\rightarrow$  EHV Consumer
- F/H  $\rightarrow$  Open Access Customer including Generators
- G  $\rightarrow$  Generator